



SAFETY & ASSEMBLY INSTRUCTION

powerCON® HC | Locking 2P+PE AC appliance coupler

IMPORTANT SAFETY INSTRUCTION



Attention: Connector without breaking capacity acc. IEC 61984 - must not be engaged or disengaged when under load or live.

FEATURES

- 250 Vac, 32 Amp (at ambient temperatures up to 35°C) / 30 Amp for cUR
- Cable O.D. 17 mm (general range: 8.0 to 20.0 mm)
- Wiring: Cable Connector: Screw-type terminals for stranded wires 6.0 mm² (AWG 10)
Chassis Connector: Screw-type terminals for wires 6.0 mm² (AWG 10)

ASSEMBLY INSTRUCTIONS | CABLE CONNECTOR

A

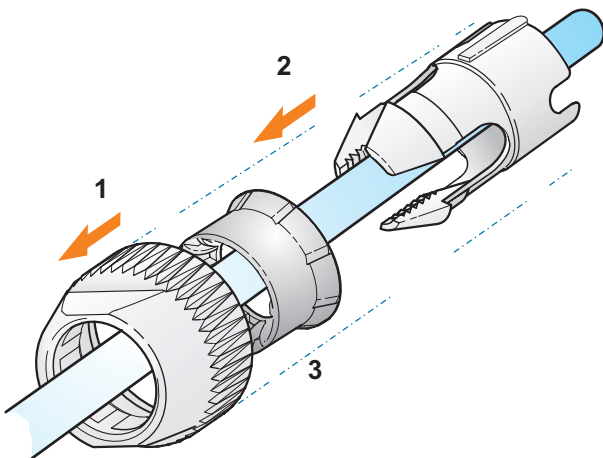

A Slide bushing (1) and chuck (2) onto the cable end.

If cable O.D.:

Less 15 mm please use reducing piece (3).

B Prepare cable as shown.

Consider excessive length of PE conductor for slackening.

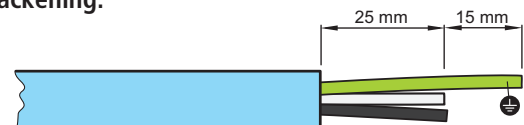

Strip the wires.



C

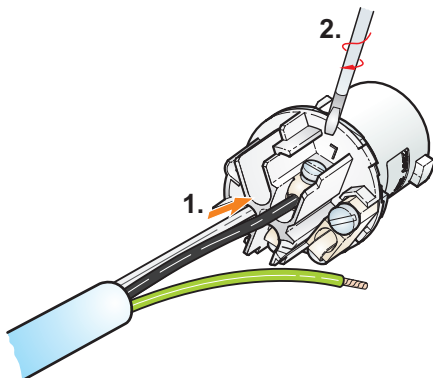

C Insert wires into terminals L, N, PE ⊕ and tighten.

ATTENTION: Max torque 180 cNm

Wiring: *

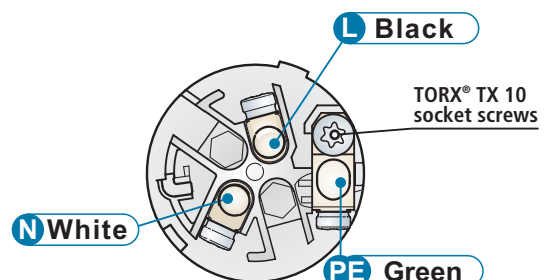



D

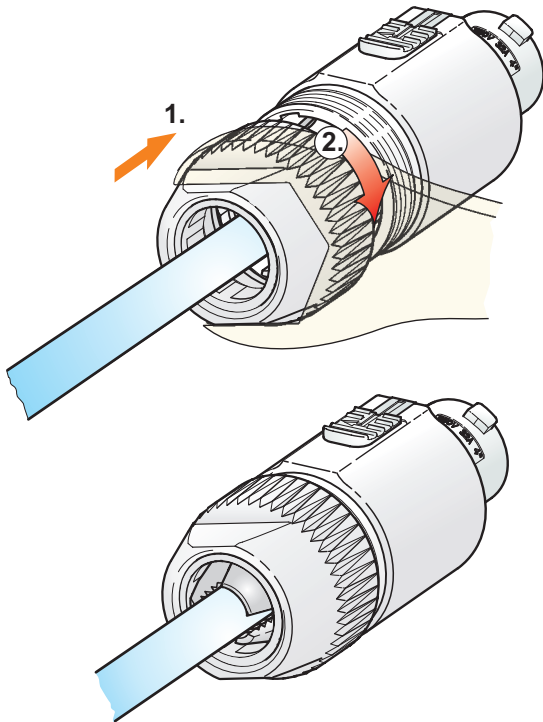

D

1. Push insert and chuck into housing.

Important: Align the chuck and insert by positioning the nose into keyway.

2. Tighten bushing using open wrench 27 mm, min. torque 3.5 Nm.

Assembled Connector

ASSEMBLY INSTRUCTIONS | RECEPTACLE

Wiring: *

Strip the wires.

Insert wires to terminals and tighten.

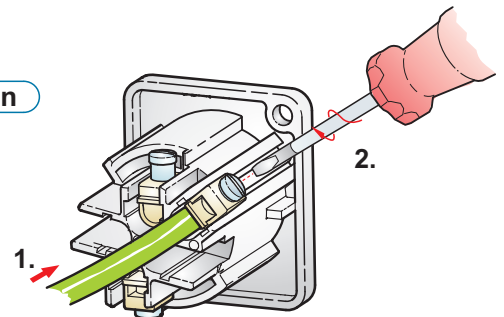
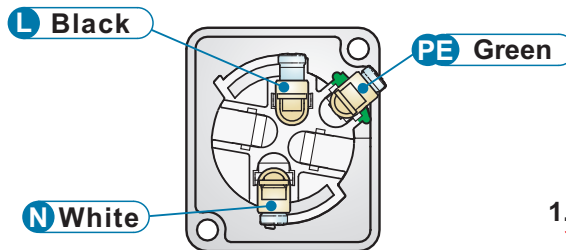
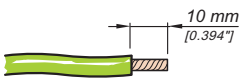

ATTENTION:

Max torque 130 cNm

Panel cutout (rear side):

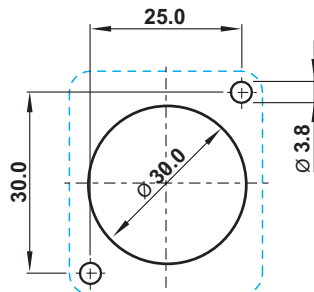

Note:

Conductor colors according to color coding of North American cords.

NEUTRIK AG	LI	T: +423 / 237 24 24	F: +423 / 232 53 93	NEUTRIK Vertriebs GmbH	DE/NL/AT/DK	T: +49 8131 / 280 890	F: +49 8131 / 280 830
NEUTRIK Zürich AG	CH	T: +41 44 / 736 5010	F: +41 44 / 736 5011	NEUTRIK France	FR	T: +33 1 / 4131 6750	F: +33 1 / 4131 0511
NEUTRIK USA Inc.	USA	T: +1 732 / 901 9488	F: +1 732 / 901 9608	NEUTRIK Tokyo Ltd.	JP	T: +81 3 / 3663 4733	F: +81 3 / 3663 4796
NEUTRIK (UK) Ltd.	UK	T: +44 1983 / 811 441	F: +44 1983 / 811 439	NEUTRIK Hong Kong Ltd.	HK	T: +852 / 2687 6055	F: +852 / 2687 6052